



ETA-Danmark A/S
Göteborg Plads 1
DK-2150 Nordhavn
Tel. +45 72 24 59 00
Fax +45 72 24 59 04
Internet www.etadanmark.dk

Authorised and notified according
to Article 29 of the Regulation (EU)
No 305/2011 of the European
Parliament and of the Council of 9
March 2011

MEMBER OF EOTA



European Technical Assessment ETA-09/0311 of 2024/03/14

General Part

Technical Assessment Body issuing the ETA and designated according to Article 29 of the Regulation (EU) No 305/2011: ETA-Danmark A/S

Trade name of the
construction product:

AV Angle Brackets without rib (type 70921, 70923,
70924, 70925, 70926, 70929) and with rib (type 70931,
70932, 70933)

Product family to which the
above construction product
belongs:

Three-dimensional nailing plate (Angle Bracket for
timber-to-timber connections)

Manufacturer:

August Vormann GmbH & Co. KG
Postfach 1552
Heilenbecker Strasse 191 - 205
DE-58256 Ennepetal
Tel. +49 02333 / 978 - 0
Internet www.vormann.com

Manufacturing plant:

August Vormann GmbH & Co. KG
Berliner Strasse 50
DE-04910 Elsterwerda

This European Technical
Assessment contains:

34 pages including 2 annexes which form an integral
part of the document

This European Technical
Assessment is issued in
accordance with Regulation
(EU) No 305/2011, on the
basis of:

EAD 130186-00-0603, Three Dimensional Nailing
Plates

This version replaces:

The ETA with the same number issued on 2015-07-02

Translations of this European Technical Assessment in other languages shall fully correspond to the original issued document and should be identified as such.

Communication of this European Technical Assessment, including transmission by electronic means, shall be in full (excepted the confidential Annex(es) referred to above). However, partial reproduction may be made, with the written consent of the issuing Technical Assessment Body. Any partial reproduction has to be identified as such

II SPECIFIC PART OF THE EUROPEAN TECHNICAL ASSESSMENT

1 Technical description of product

AV angle brackets with and without rib are one-piece non-welded, face-fixed angle brackets to be used in timber to timber connections. They are connected to construction members made of timber or wood-based products by a range of profiled (ringed shank) nails according to EN 14592 or an ETA.

The angle brackets are made from pre-galvanized steel S 250 GD / Z 275 according to EN 10346:2009 with $R_{p0,2} \geq 250 \text{ N/mm}^2$, $R_m \geq 330 \text{ N/mm}^2$ or from stainless steel according to EN 10088-2:2014 with $R_{p0,2} \geq 240 \text{ N/mm}^2$ and $R_m \geq 500 \text{ N/mm}^2$ and are available with or without an embossed rib. Dimensions, hole positions and typical installations are shown in Annex A. AV angle brackets are made from steel with tolerances according to EN 10143.

2 Specification of the intended use in accordance with the applicable European Assessment Document (hereinafter EAD)

The angle brackets are intended for use in making connections in load bearing timber structures, as a connection between a beam and a purlin or a column, where requirements for mechanical resistance and stability and safety in use in the sense of the Basic Work Requirements 1 and 4 of the Regulation 305/2011 (EU) shall be fulfilled.

The connection may be with a single angle bracket or with an angle bracket on each side of the fastened timber member (see Annex A).

The static and kinematical behaviour of the timber members or the supports shall be as described in Annex B.

The wood members may be of solid timber, glued laminated timber and similar glued members, or wood-based structural members with a characteristic density from 290 kg/m^3 to 420 kg/m^3 . This requirement to the material of the wood members can be fulfilled by using the following materials:

- Structural solid timber according to EN 14081,
- Glulam according to EN 14080,
- LVL according to EN 14374,
- Parallam PSL,
- Intrallam LSL,
- Cross laminated timber,
- Glued solid timber according to EN 14080,
- Plywood according to EN 636

Annex B states the load-carrying capacities of the angle bracket connections for a characteristic density of 350 kg/m^3 . For timber or wood based material with a lower characteristic density than 350 kg/m^3 the load-carrying capacities shall be reduced by the k_{dens} factor:

$$k_{\text{dens}} = \left(\frac{\rho_k}{350} \right)^2$$

Where ρ_k is the characteristic density of the timber in kg/m^3 .

The design of the connections shall be in accordance with Eurocode 5 or a similar national Timber Code. The wood members shall have a thickness which is larger than the penetration depth of the nails into the members.

The angle brackets are primarily for use in timber structures subject to the dry, internal conditions defined by service classes 1 and 2 of Eurocode 5 and for connections subject to static or quasi-static loading.

The angle brackets can also be used in outdoor timber structures, service class 3, when a corrosion protection in accordance with Eurocode 5 is applied, or when stainless steel with similar or better characteristic yield and ultimate strength is employed.

To avoid contact corrosion, stainless steel angle brackets shall be used with nails made from stainless steel.

The scope of the connectors regarding resistance to corrosion shall be defined according to national provisions that apply at the installation site considering environmental conditions and in conjunction with the admissible service conditions according to EN 1995-1-1 and the admissible corrosivity category as described and defined in EN ISO 12944-2.

The angle brackets are used for timber to timber connections.

Assumed working life

The assumed intended working life of the angle brackets for the intended use is 50 years, provided that they are subject to appropriate use and maintenance.

The information on the working life should not be regarded as a guarantee provided by the manufacturer or ETA Denmark. An “assumed intended working life” means that it is expected that, when this working life has elapsed, the real working life may be, in normal use conditions, considerably longer without major degradation affecting the essential requirements.

3 Performance of the product and references to the methods used for its assessment

Characteristic	Assessment of characteristic
3.1 Mechanical resistance and stability*) (BWR1)	
Joint Strength - Characteristic load-carrying capacity	See Annex B
Joint Stiffness	See Annex B
Joint ductility	No performance assessed
Resistance to seismic actions	No performance assessed
Resistance to corrosion and deterioration	See section 3.6
3.2 Safety in case of fire (BWR2)	
Reaction to fire	The angle brackets are made from steel classified as Euroclass A1 in accordance with EN 13501-1 and Commission Delegated Regulation 2016/364
Resistance to fire	No performance assessed
3.3 General aspects related to the performance of the product	
	The angle brackets have been assessed as having satisfactory durability and serviceability when used in timber structures using the timber species described in Eurocode 5 and subject to the conditions defined by service class 1, 2 and 3

*) See additional information in section 3.4 – 3.7

3.4 Methods of verification

Safety principles and partial factors

The characteristic load-carrying capacities are based on the characteristic values of the nail connections and the steel plates. To obtain design values the capacities have to be divided by different partial factors for the material properties, the nail connection in addition multiplied with the coefficient k_{mod} .

According to EN 1990 (Eurocode – Basis of design) paragraph 6.3.5 the design value of load-carrying capacity may be determined by reducing the characteristic values of the load-carrying capacity with different partial factors.

Thus, the characteristic values of the load-carrying capacity are determined also for timber failure $F_{Rk,H}$ (obtaining the embedment strength of nails subjected to shear or the withdrawal capacity of the most loaded nail, respectively) as well as for steel plate failure $F_{Rk,S}$. The design value of the load-carrying capacity is the smaller value of both load-carrying capacities.

$$F_{Rd} = \min \left\{ \frac{k_{mod} \cdot F_{Rk,H}}{\gamma_{M,H}}, \frac{F_{Rk,S}}{\gamma_{M,S}} \right\}$$

Therefore, for timber failure the load duration class and the service class are included. The different partial factors γ_M for steel or timber, respectively, are also correctly taken into account.

3.5 Mechanical resistance and stability

See annex B for the characteristic load-carrying capacity in the different directions F_1 to F_5 .

The characteristic capacities of the angle brackets are determined by calculation assisted by testing as described in EAD 130186-00-0603 clause 2.2.1. They should be used for designs in accordance with Eurocode 5 or a similar national Timber Code.

Threaded nails (ringed shank nails) in accordance to EN 14592 or an ETA

In the formulas in Annex B the capacities for threaded nails calculated from the formulas of Eurocode 5 are used assuming a thick steel plate when calculating the lateral nail load-carrying-capacity.

The load bearing capacities of the brackets has been determined based on the use of connector nails 4,0 x 40 mm in accordance with the German national specification for the nails.

The shape of the nail directly under the head shall be in the form of a truncated cone with a diameter under the nail head which exceeds the hole diameter.

The design models allow the use of fasteners described in the Table A.3 on page 9 in Annex A.

No performance has been determined in relation to ductility of a joint under cyclic testing. The contribution to the performance of structures in seismic zones, therefore, has not been assessed.

No performance has been determined in relation to the joint's stiffness properties - to be used for the analysis of the serviceability limit state.

3.6 Aspects related to the performance of the product

Corrosion protection in service class 1 and 2.

In accordance with EAD 130186-00-0603 the angle brackets are made from pre-galvanized steel S 250 GD / Z 275 according to EN 10346:2009 with $R_{p0,2} \geq 250$ N/mm², $R_m \leq 330$ N/mm² or from stainless steel according to EN 10088-2:2014 with $R_{p0,2} \geq 240$ N/mm² and $R_m \geq 500$ N/mm².

Corrosion protection in service class 3.

In accordance with EAD 130186-00-0603 the angle brackets are made from stainless steel according to EN 10088-2:2014 with $R_{p0,2} \geq 240$ N/mm² and $R_m \geq 500$ N/mm².

3.7 General aspects related to the use of the product

AV angle brackets are manufactured in accordance with the provisions of this European Technical Assessment using the manufacturing processes as identified in the inspection of the plant by the notified inspection body and laid down in the technical documentation

AV angle brackets

The following provisions concerning installation apply:

The structural members – the components 1 and 2 shown in the figure on page 33 - to which the brackets are fixed shall be:

- Restrained against rotation. At a load F_4/F_5 and arrangement of two brackets per connection, the component 2 is allowed to be restrained against rotation by the angle brackets.
- Strength class C14 or better, see section 1 of this ETA
- Free from wane under the bracket.
- The actual end bearing capacity of the timber member to be used in conjunction with the bracket is checked by the designer of the structure to ensure it is not less than the bracket capacity and, if necessary, the bracket capacity reduced accordingly.
- The gap between the timber members does not exceed 3 mm.

- There are no specific requirements relating to preparation of the timber members.

The execution of the connection shall be in accordance with the approval holder's technical literature.

4 Assessment and verification of constancy of performance (hereinafter AVCP) system applied, with reference to its legal base

4.1 AVCP system

According to the decision 97/638/EC of the European Commission¹, as amended, the system(s) of assessment and verification of constancy of performance (see Annex V to Regulation (EU) No 305/2011) is 2+.

5 Technical details necessary for the implementation of the AVCP system, as provided for in the applicable EAD

Technical details necessary for the implementation of the AVCP system are laid down in the control plan deposited at ETA-Danmark

Issued in Copenhagen on 2024-03-14 by



Thomas Bruun
Managing Director, ETA-Danmark

Annex A
Product details and definitions

Table A.1 Materials specification

Bracket number	Bracket type	Thickness (mm)	Steel specification	Coating specification on the steel brackets
070 921 000	50x50x35	2,5	S250GD/stainless steel	Z 275 / -
070 923 000	60x60x45	2,5	S250GD/stainless steel	Z 275 / -
070 924 000	70x70x55	2,0	stainless steel	-
070 924 000	70x70x55	2,5	S250GD/stainless steel	Z 275 / -
070 925 000	90x90x65	2,0	stainless steel	-
070 925 000	90x90x65	2,5	S250GD/stainless steel	Z 275 / -
070 926 000	103x103x90	2,5	stainless steel	-
070 926 000	103x103x90	3,0	S250GD/stainless steel	Z 275 / -
070 929 000	90x90x40	2,5	stainless steel	-
070 929 000	90x90x40	2,5	S250GD/stainless steel	Z 275 / -
070 931 000	70x70x55 with rib	2,0	stainless steel	-
070 931 000	70x70x55 with rib	2,5	S250GD/stainless steel	Z 275 / -
070 932 000	90x90x65 with rib	2,0	stainless steel	-
070 932 000	90x90x65 with rib	2,5	S250GD/stainless steel	Z 275 / -
070 933 000	105x105x90 with rib	2,5	stainless steel	-
070 933 000	105x105x90 with rib	3,0	S250GD/stainless steel	Z 275 / -

Table A.2 Range of sizes

Bracket number	Bracket type	Height (mm) vertical		Height (mm) horizontal		Width (mm)	
		min	max	min	max	min	max
070 921 000	50x50x35	49,4	50,6	49,4	50,6	34,4	35,6
070 923 000	60x60x45	59,4	60,6	59,4	60,6	44,4	45,6
070 924 000	70x70x55	69	71	69	71	54	56
070 925 000	90x90x65	89	91	89	91	64	66
070 926 000	105x105x90	104	106	104	106	89	91
070 929 000	90x90x40	89,2	90,8	89,2	90,8	39,4	40,6
070 931 000	70x70x55 with rib	68	71	68	71	51,5	56
070 932 000	90x90x65 with rib	88	91	88	91	60	66
070 933 000	105x105x90 with rib	103	106	103	106	87	91

Table A.3 Fastener specification

Nail type	Nail size (mm)			Finish
	Diameter	Length	Threaded length	
According to EN 14592 or an ETA				
Threaded nail	4,0	40	31	Electroplated zinc / stainless steel
The shape of the nail directly under the head shall be in the form of a truncated cone with a diameter under the nail head which exceeds the hole diameter.				

AV angle brackets

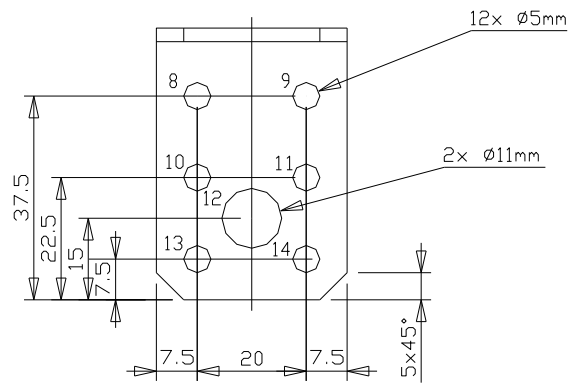
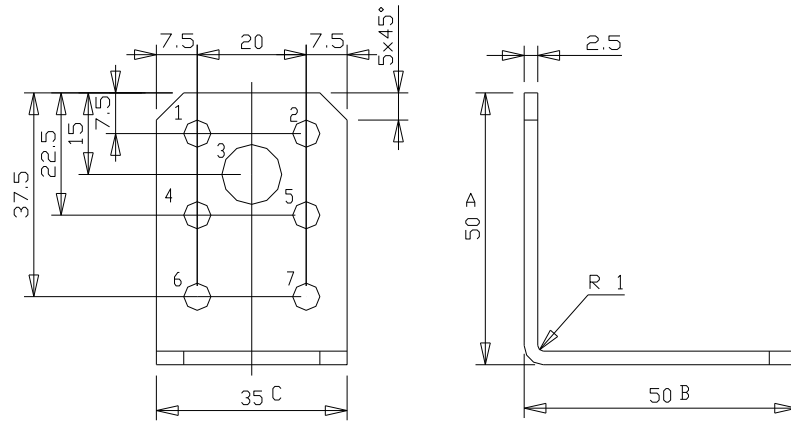

August Vormann
GmbH&Co.KG
Heilenbeckerstr.
58256 Ennepetal

Winkelverbinder
70921

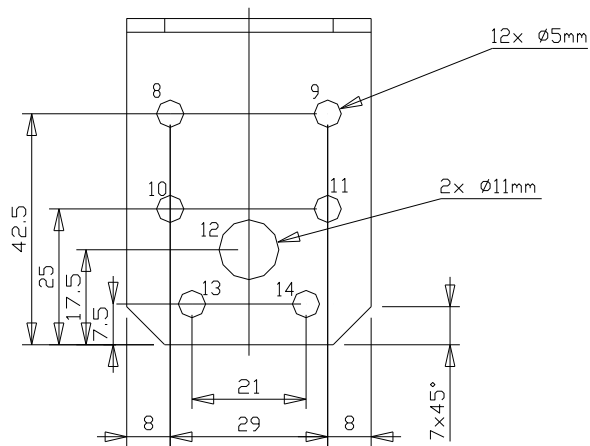
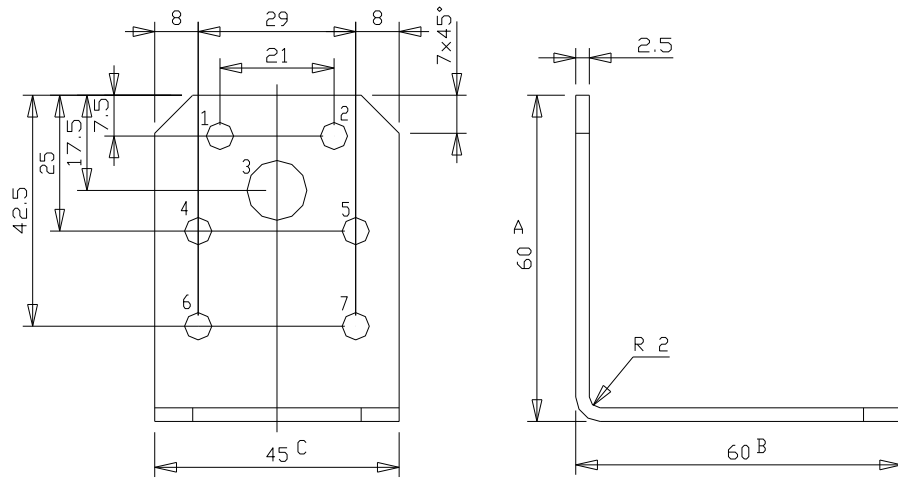

August Vormann
GmbH&Co.KG
Heilenbeckerstr.
58256 Ennepetal

Winkelverbinder
70923

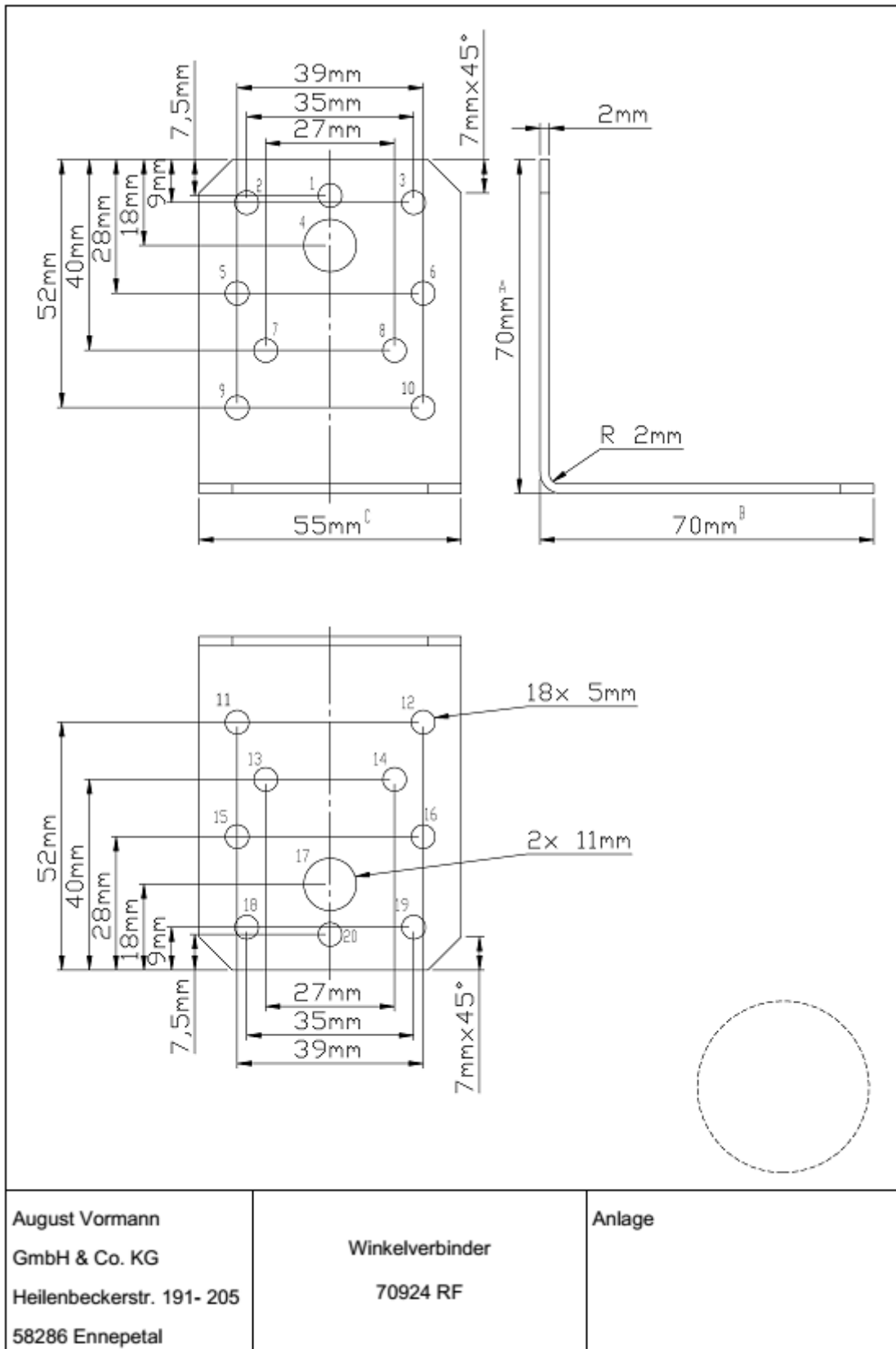

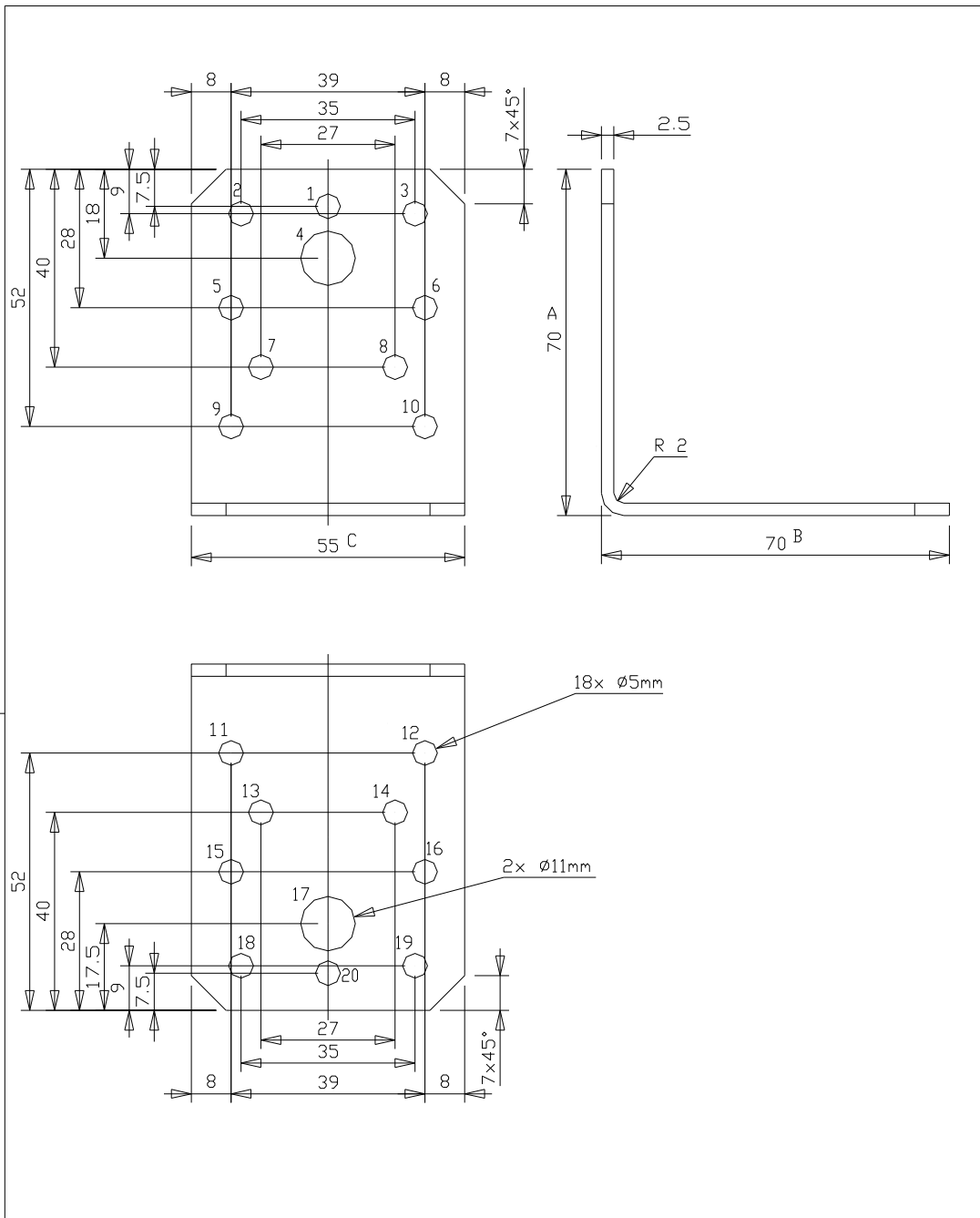

<p>August Vormann GmbH&Co.KG Heilenbeckerstr. 58256 Ennepetal</p>	<p>Winkelverbinder 70924</p>	
---	----------------------------------	--

Speicher Code: /z/hvl/70924so

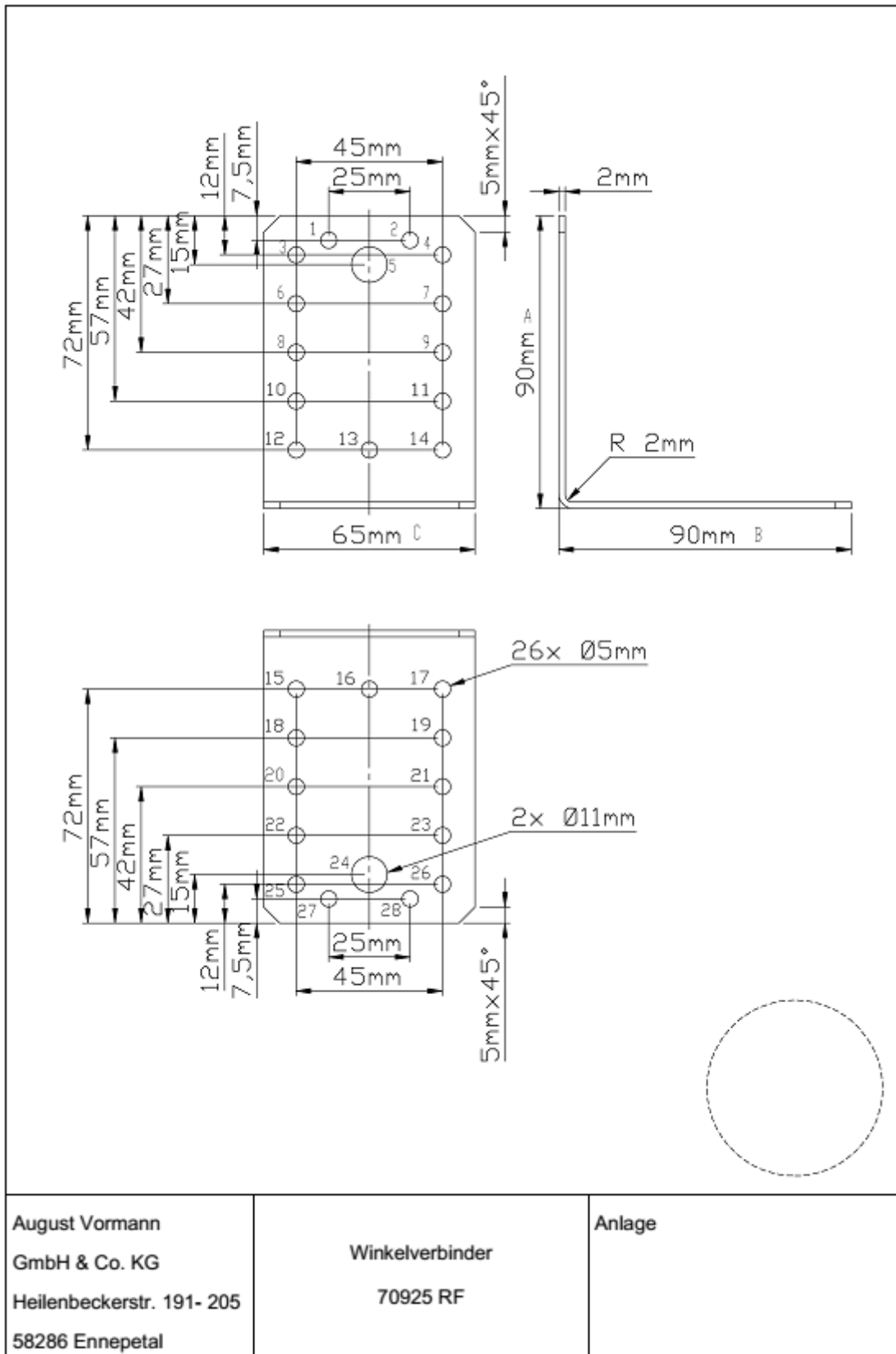

<p>August Vormann GmbH & Co. KG Heilenbeckerstr. 191- 205 58286 Ennepetal</p>	<p>Winkelverbinder 70925 RF</p>	<p>Anlage</p>
--	--	---------------

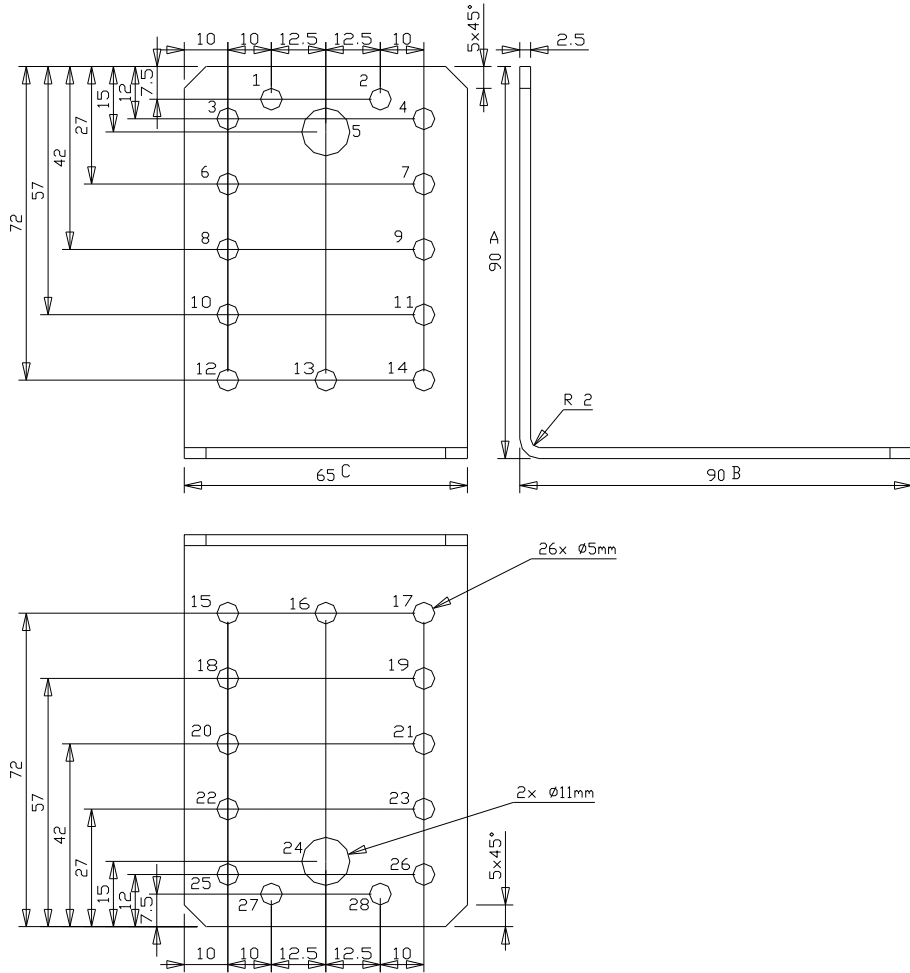

August Vormann
 GmbH&Co.KG
 Heilenbeckerstr.
 58256 Ennepetal

Winkelverbinder
 70925

Speicher Code: /z/hv1/70925so

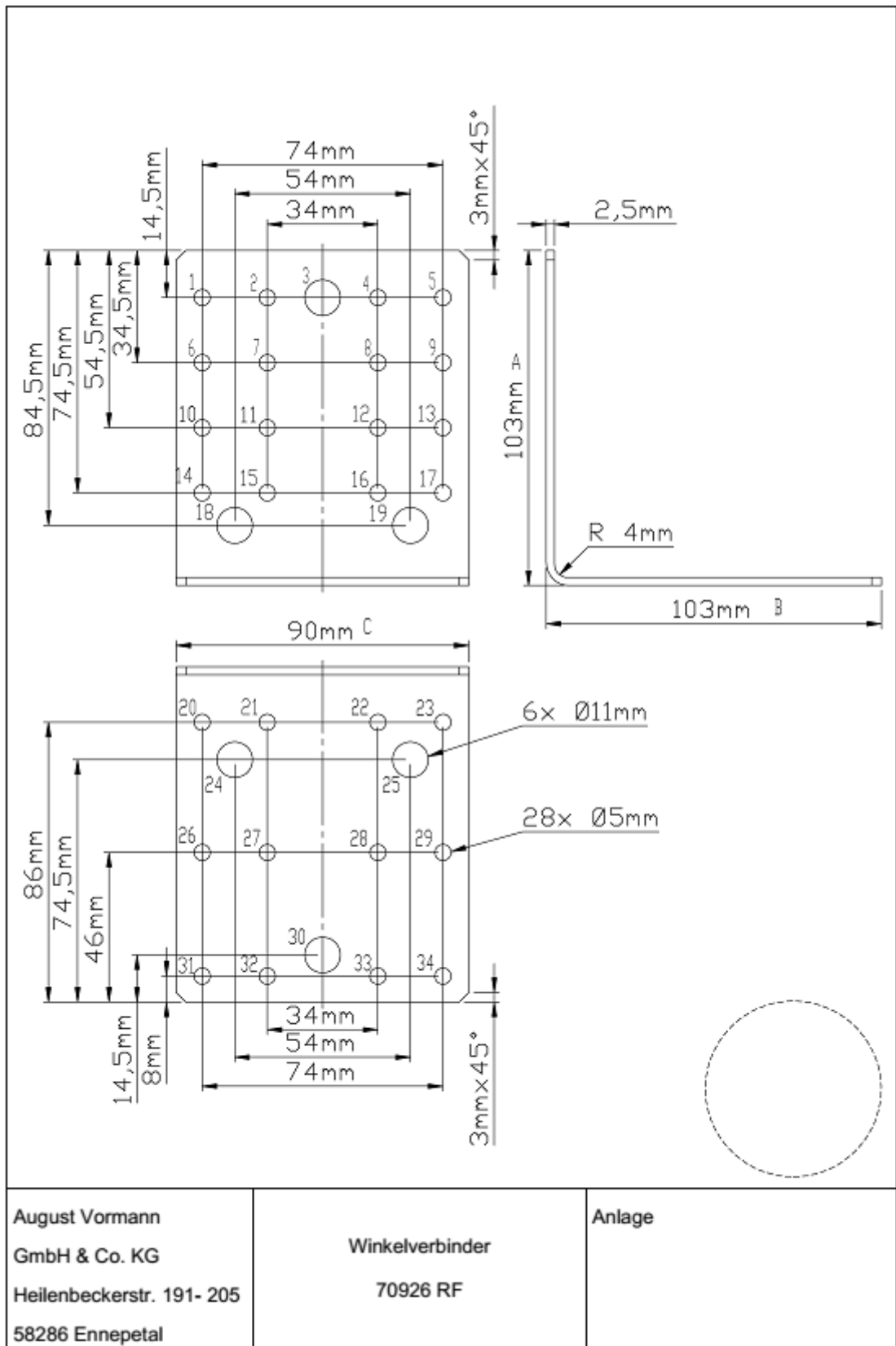

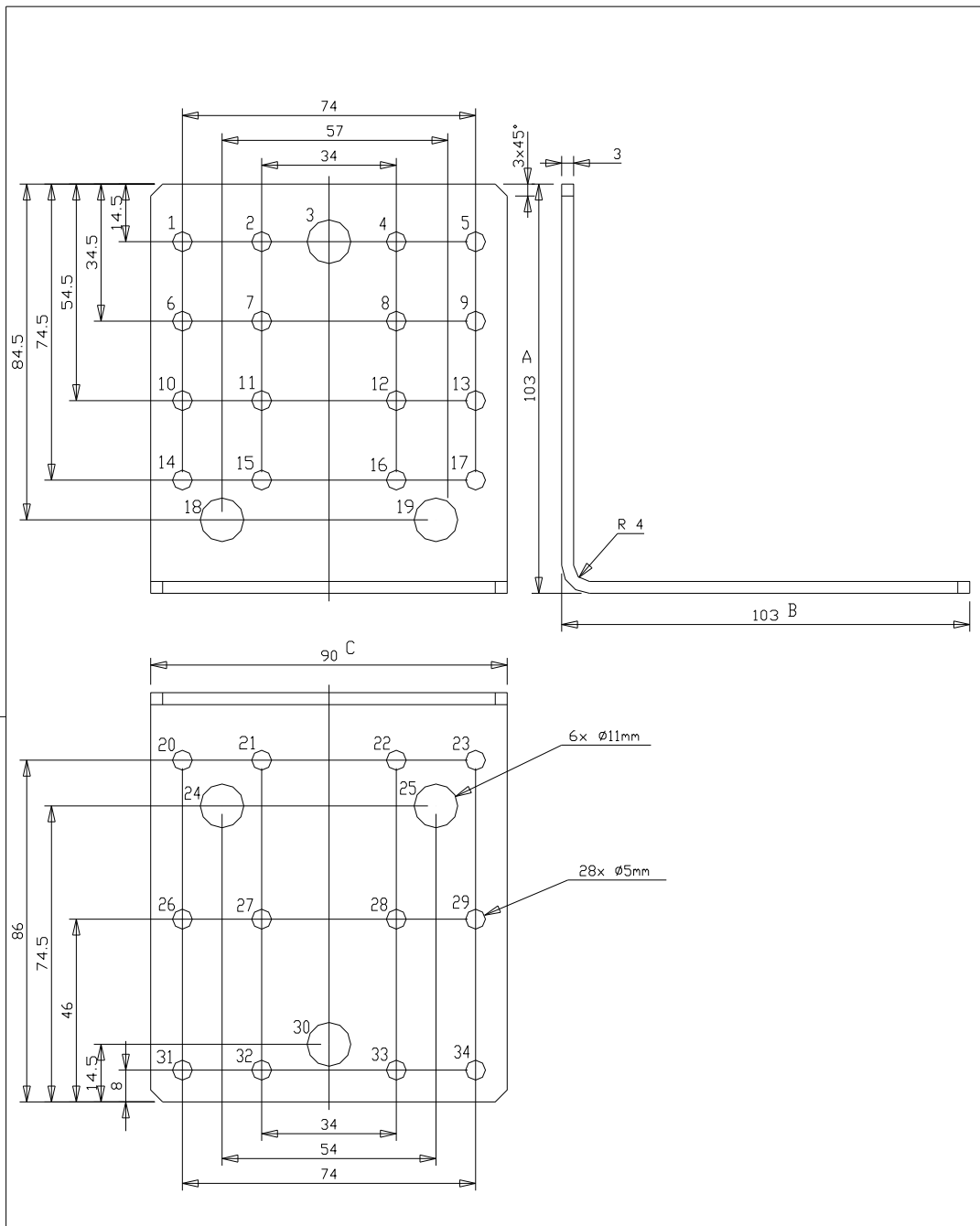

August Vormann
GmbH&Co.KG
Heilenbeckerstr.
58256 Ennepetal

Winkelverbinder
70926

Speicher Code: /z/hv1/70926so

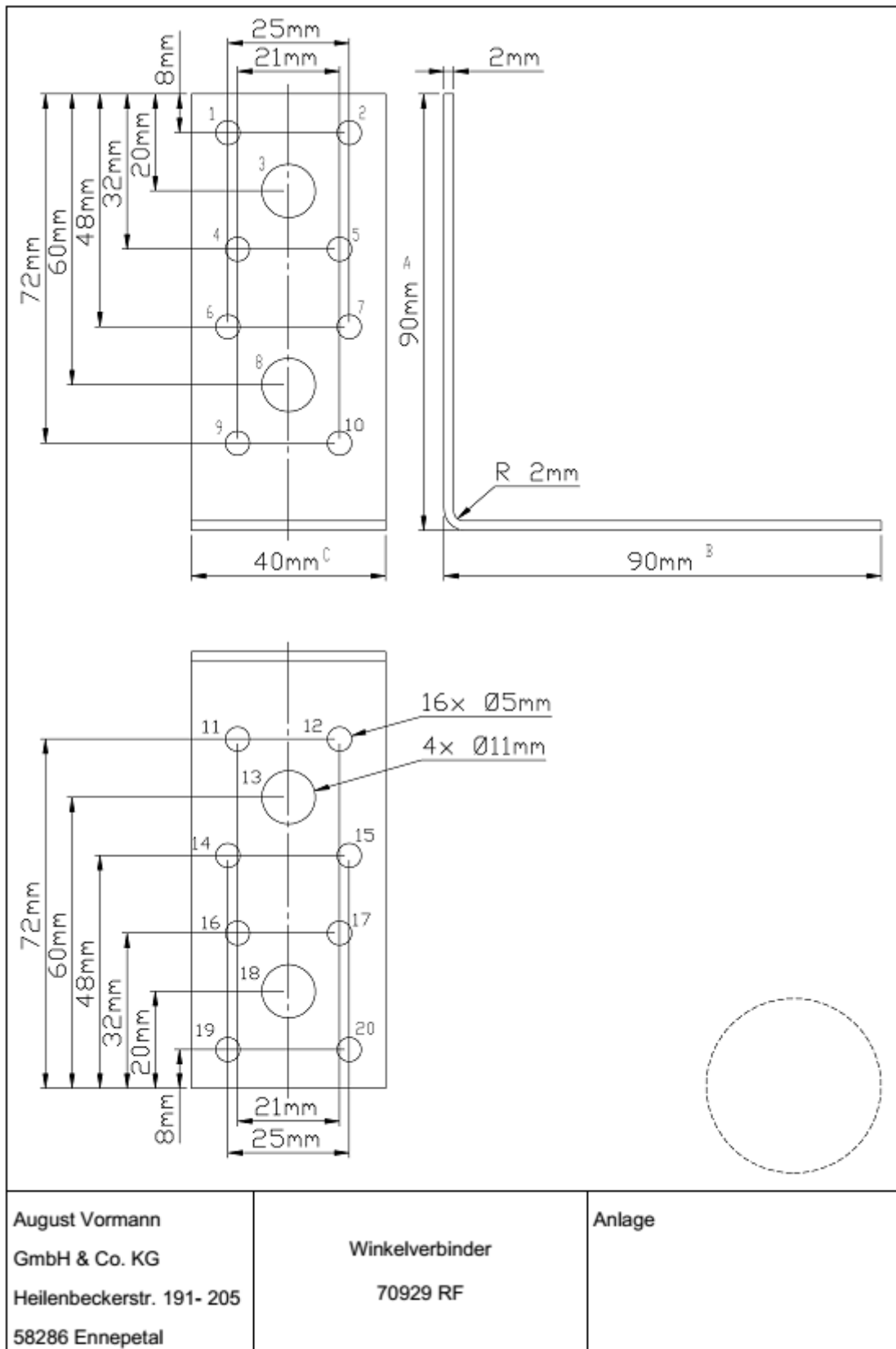

August Vormann
 GmbH & Co. KG
 Heilenbeckerstr. 191- 205
 58286 Ennepetal

Winkelverbinder
 70929 RF

Anlage

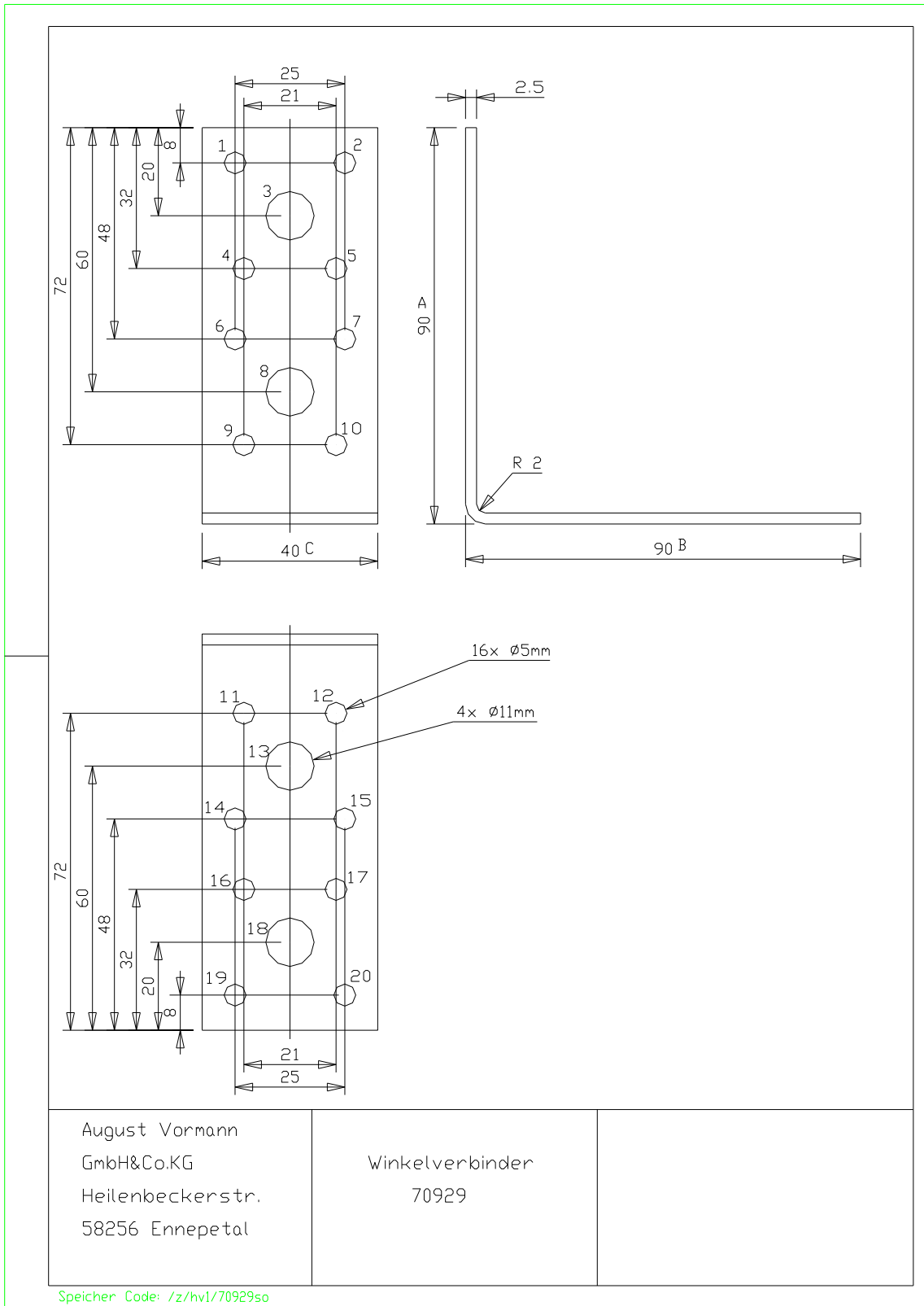

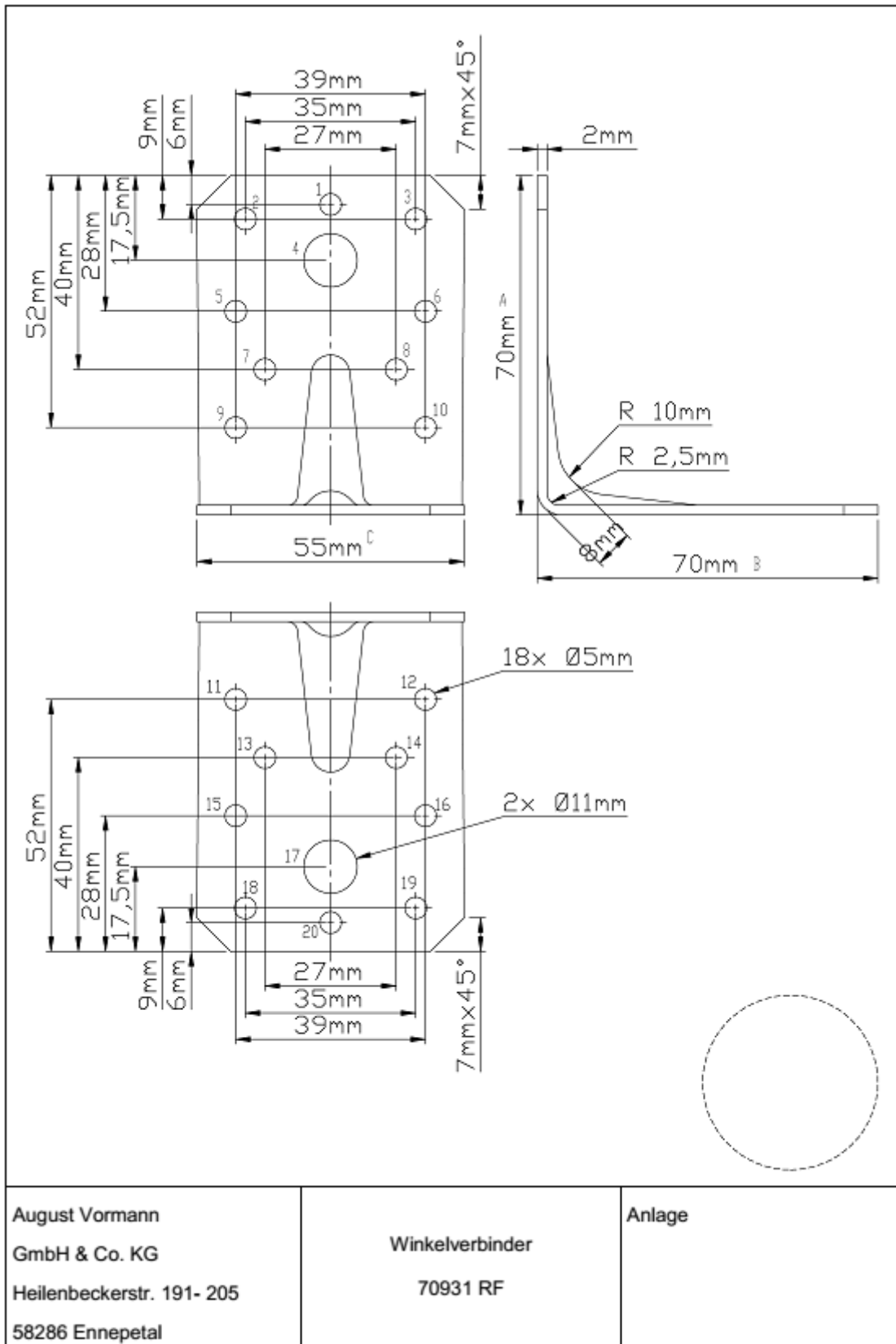

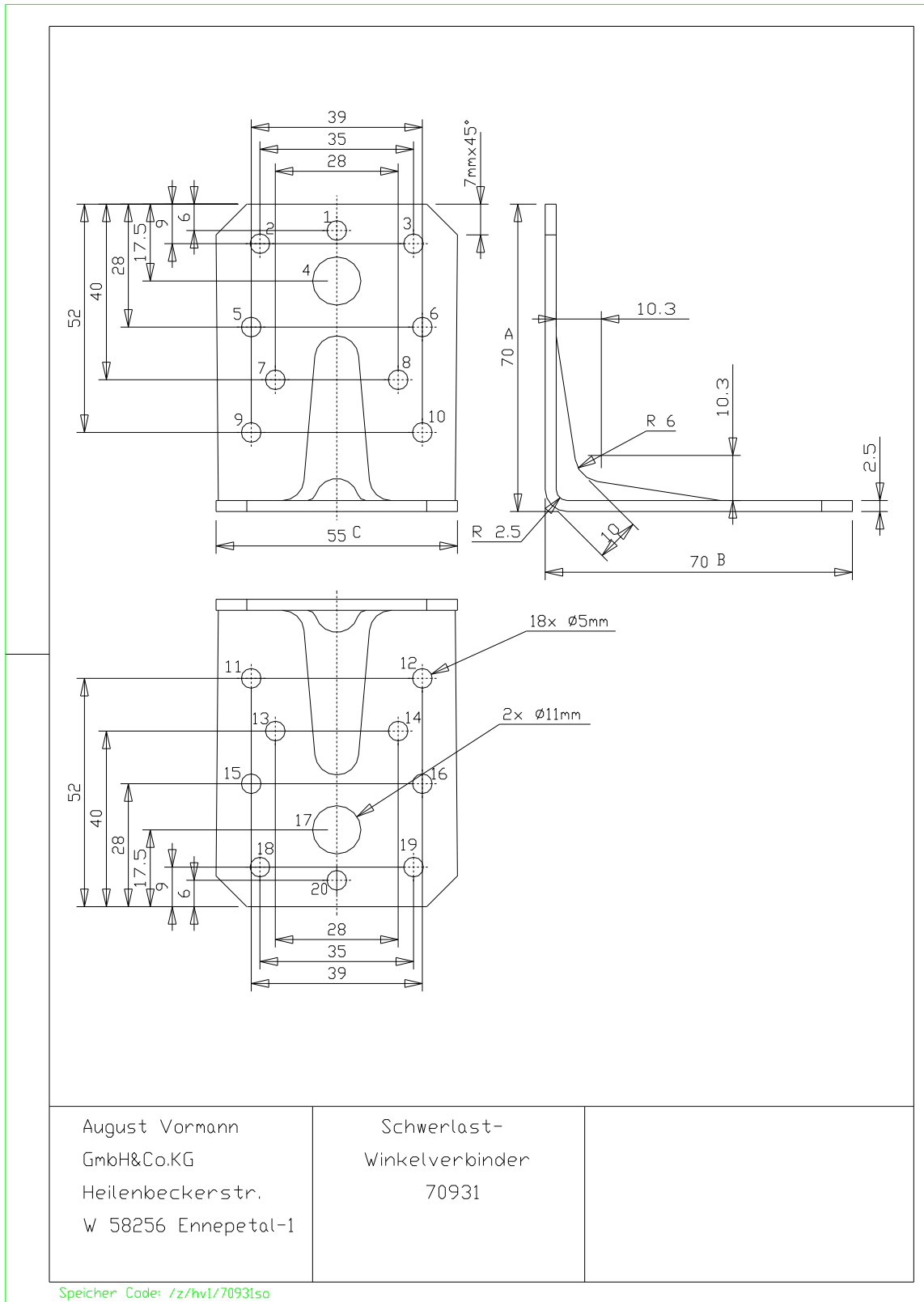

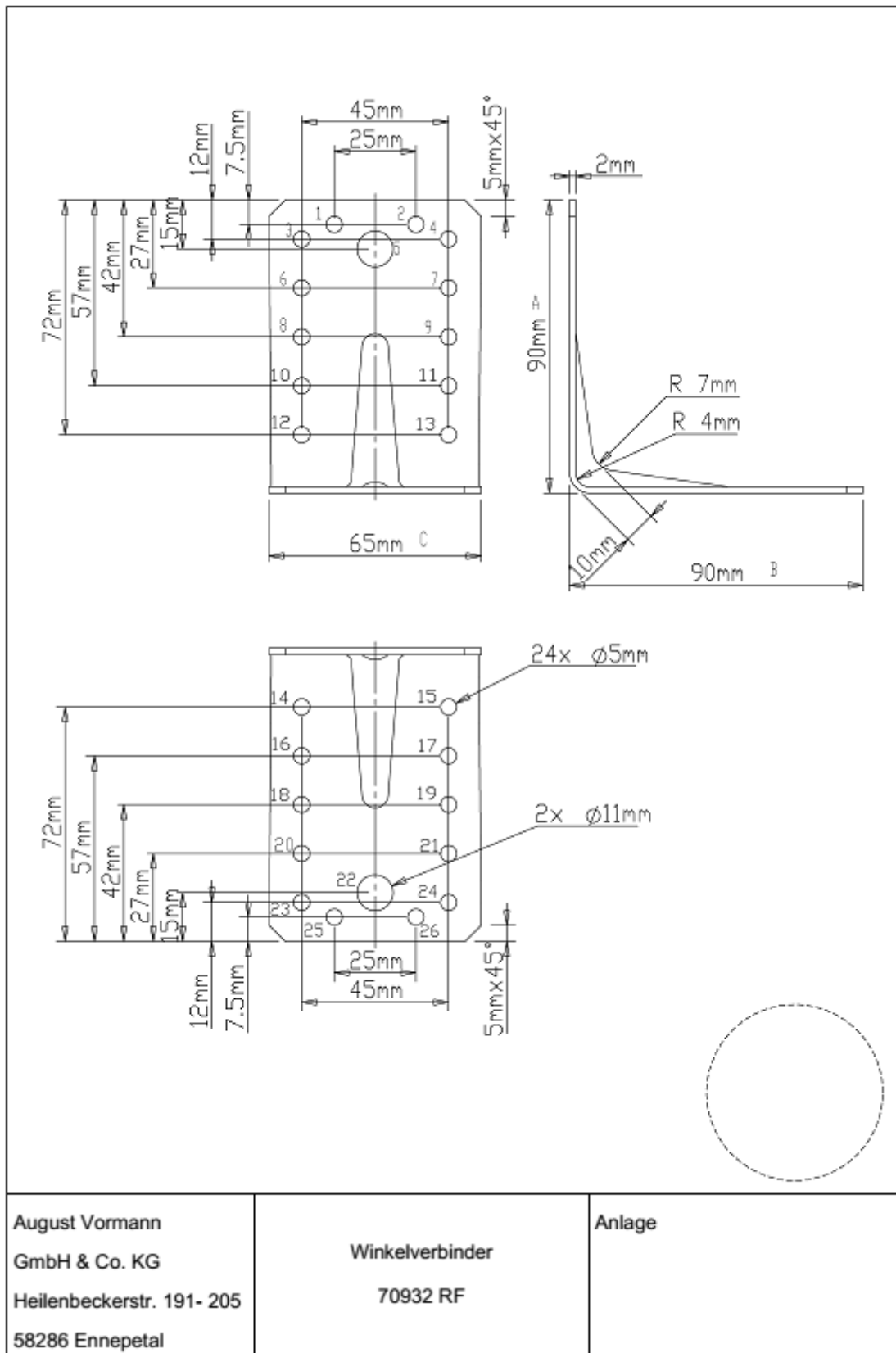

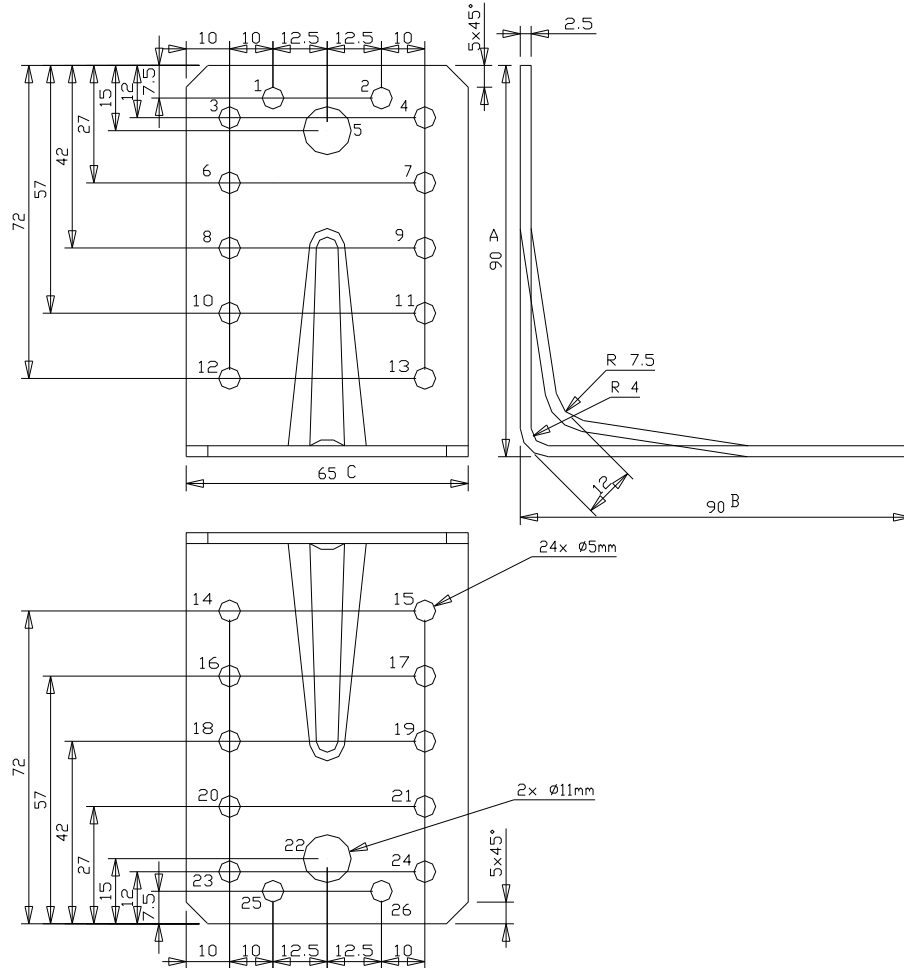

August Vormann
 GmbH&Co.KG
 Heilenbeckerstr.
 58256 Ennepetal

Schwerlast-
 Winkelverbinder
 70932

Speicher Code: /z/hv1/70932so

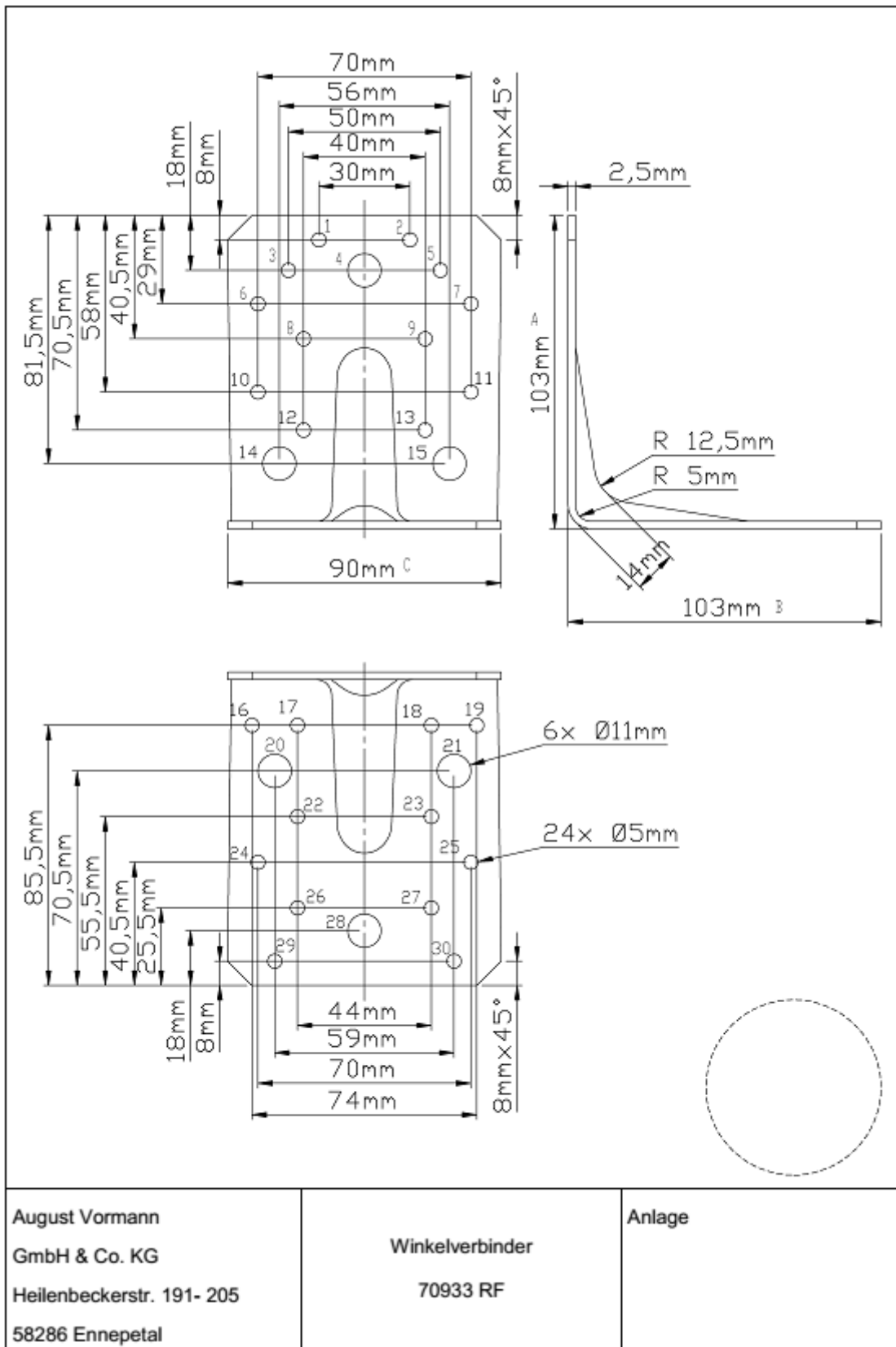

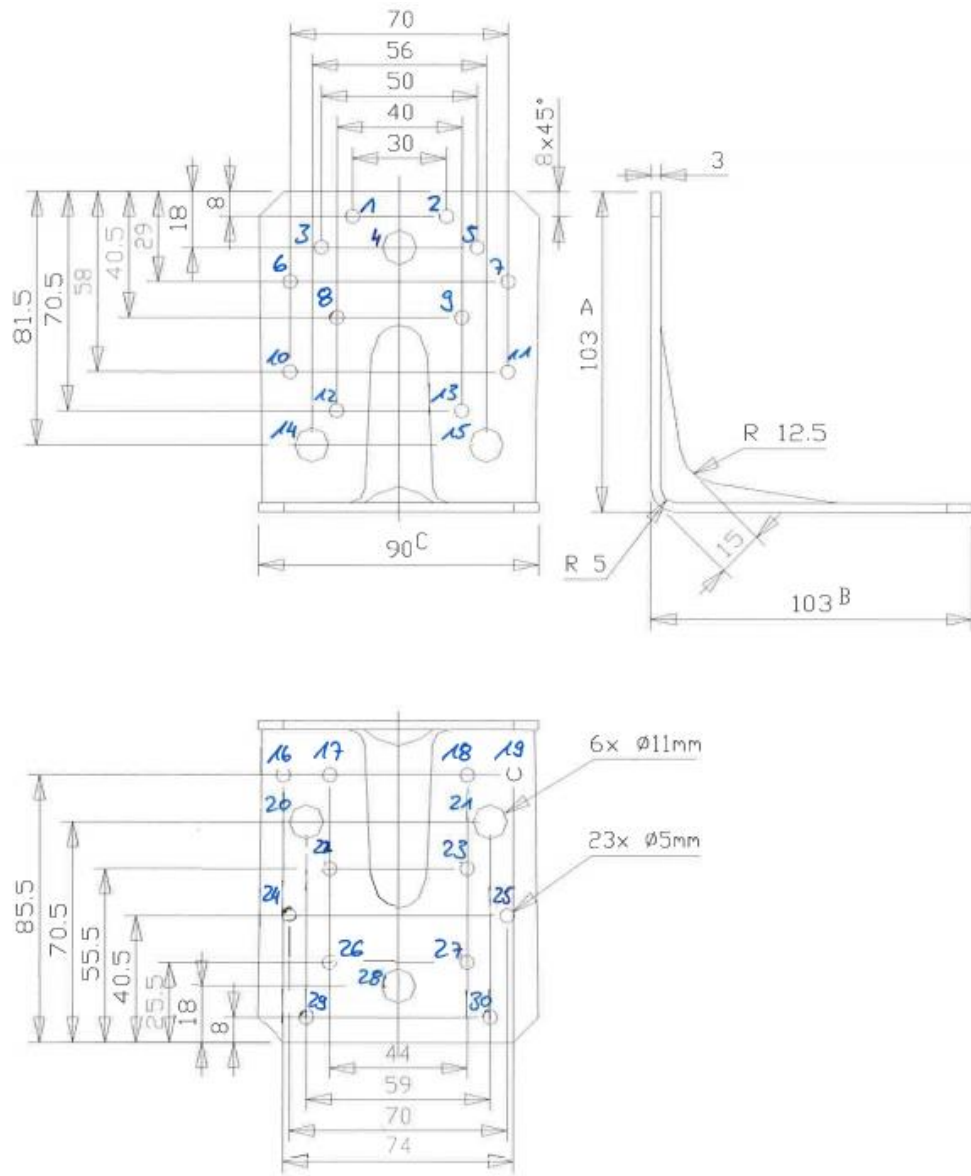

070 933 000 with 103 x 103 x 90 x 3.0 mm

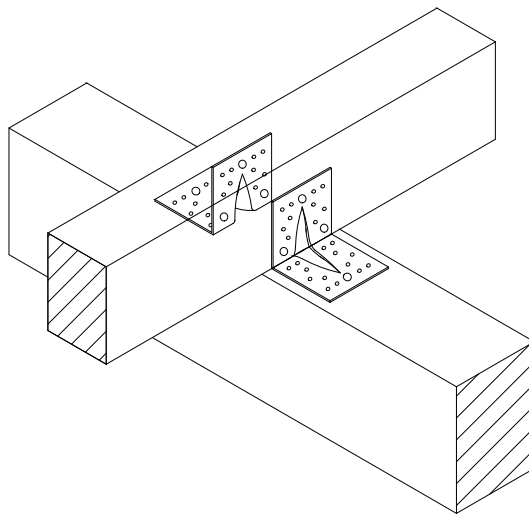

Figure A.1: Typical installation

Annex B Characteristic load-carrying capacities

The following tables contain the characteristic values for the load carrying capacities of the angle brackets for the column or purlin and beam connections. The minimum rated value resulting from timber failure and steel failure is applicable. It must be ensured that the timber members are restrained against rotation. The hole numbers specified must be provided with nails.

The values in the following tables are valid for threaded nails 4,0 x 40 mm with $F_{ax,Rk} = 686$ N and $M_{y,Rk} = 6617$ Nmm.

S 250 GD / Z275 Steel brackets

Table 1: Force F_1 Column, 2 angle brackets / connection, Timber to timber

Bracket number	Nail number n_V	Nail number n_H	$F_{1,Rk}$ [kN] (column)	
			Timber	Steel
070 921 000 50x50x35x2,5	-	-	-	-
070 923 000 60x60x45x2,5	1,2	8,9,13,14	2,11	1,53
070 924 000 70x70x55x2,5	1,2,3	11,12,15,16,18,19	2,20	1,95
070 925 000 90x90x65x2,5	1,2,6,7	15,16,17,20,21,25,26	3,59	2,17
070 926 000 103x103x90x3,0	1,2,4,5,6,7,8,9	20,21,22,23,26,27,28,29,31,32,33,34	5,02	4,63
070 929 000 90x90x40x2,5	1,2,4,5	11,12,14,15,16,17,19,20	2,39	1,30
070 931 000 70x70x55x2,5	1,2,3	11,12,15,16,18,19	3,18	3,46
070 932 000 90x90x65x2,5	1,2,6,7	14,15,18,19,23,24	4,05	4,53
070 933 000 103x103x90x3,0	1,2,6,7	16,17,18,19,22,23,24,25,29,30	5,72	16,50

The table contains the characteristic values of the load carrying capacity for a column connection. Values must be halved for one joint per connection.

Table 2: Force F_1 Purlin, 2 angle brackets / connection, Timber to timber

Bracket number	Nail number n_V	Nail number n_H	$F_{1,Rk}$ [kN] (purlin)	
			Timber	Steel
070 921 000 50x50x35x2,5	1,2	8,9,13,14	2,25	1,58
070 923 000 60x60x45x2,5	1,2,4,5	8,9,13,14	2,11	1,53
070 924 000 70x70x55x2,5	2,3,7,8	11,12,15,16,18,19	2,20	1,95
070 925 000 90x90x65x2,5	3,4,6,7,8,9,10,11	15,16,17,20,21,25,26	3,59	2,17

070 926 000 103x103x90x3,0	1,2,4,5,6,7,8,9, 10,11,12,13,14,15,16,17	20,21,22,23,26,27,28,29,31,32,33,34	5,02	4,63
070 929 000 90x90x40x2,5	1,2,4,5,6,7	11,12,14,15,16,17,19,20	2,39	1,30
070 931 000 70x70x55x2,5	2,3,7,8	11,12,15,16,18,19	3,18	3,46
070 932 000 90x90x65x2,5	3,4,6,7,8,9,10,11	14,15,18,19,23,24	4,05	4,53
070 933 000 103x103x90x3,0	1,2,6,7,8,9,10,11,12,13	16,17,18,19,22,23,24,25,29,30	5,72	16,50

The table contains the characteristic values of the load carrying capacity for a purlin connection. Values must be halved for one joint per connection.

Table 3: Forces $F_{2,3}$, 2 angle brackets / connection, Timber to timber

Bracket number	Nail number n_V	Nail number n_H	$F_{2,3,Rk}$ [kN]	
			Timber	
070 921 000 50x50x35x2,5	1,2,4,5	8,9,13,14	4,39	
070 923 000 60x60x45x2,5	1,2,4,5	8,9,13,14	3,99	
070 924 000 70x70x55x2,5	2,3,7,8	11,12,15,16,18,19	5,89	
070 925 000 90x90x65x2,5	3,4,6,7,8,9,10,11	15,16,17,20,21,25,26	8,68	
070 926 000 103x103x90x3,0	1,2,4,5,6,7,8,9, 10,11,12,13,14,15,16,17	20,21,22,23,26,27,28,29,31,32,33,34	15,50	
070 929 000 90x90x40x2,5	1,2,4,5,6,7	11,12,14,15,16,17,19,20	5,41	
070 931 000 70x70x55x2,5	2,3,7,8	11,12,15,16,18,19	5,89	
070 932 000 90x90x65x2,5	3,4,6,7,8,9,10,11	14,15,18,19,23,24	7,72	
070 933 000 103x103x90x3,0	1,2,6,7,8,9,10,11,12,13	16,17,18,19,22,23,24,25,29,30	11,50	

The table contains the characteristic values of the load carrying capacity for a purlin connection. Values must be halved for one joint per connection.

Table 4: Basic Forces $F_{4,5}$, 2 angle brackets / connection, Timber to timber

Bracket number	Nail number n_V	Nail number n_H	$F_{4,5,Rk}$ [kN]	
			Timber	Steel
070 921 000 50x50x35x2,5	1,2,4,5	8,9,13,14	4,47	1,96
070 923 000 60x60x45x2,5	1,2,4,5	8,9,13,14	5,00	2,61

070 924 000 70x70x55x2,5	2,3,7,8	11,12,15,16,18,19	5,24	3,72
070 925 000 90x90x65x2,5	3,4,6,7,8,9,10,11	15,16,17,20,21,25,26	6,87	4,13
070 926 000 103x103x90x3,0	1,2,4,5,6,7,8,9, 10,11,12,13,14,15,16,17	20,21,22,23,26,27,28,29,31,32,33,34	11,40	7,79
070 929 000 90x90x40x2,5	1,2,4,5,6,7	11,12,14,15,16,17,19,20	4,80	2,34
070 931 000 70x70x55x2,5	2,3,7,8	11,12,15,16,18,19	5,51	4,85
070 932 000 90x90x65x2,5	3,4,6,7,8,9,10,11	14,15,18,19,23,24	7,17	5,65
070 933 000 103x103x90x3,0	1,2,6,7,8,9,10,11,12,13	16,17,18,19,22,23,24,25,29,30	10,60	11,10

The table contains the characteristic values of the load carrying capacity for a purlin connection. Load case $F_{4/5}$ describes a connection with two angle joints per connection. The component 2 is allowed to be restrained against rotation by the angle brackets. In this case, an additional force ΔF_1 has to be considered.

Table 5: Basic Forces F_4 , 1 angle bracket / connection, Timber to timber

Bracket number	Nail number n_V	Nail number n_H	$F_{4,Rk}$ [kN]	
			Timber	Steel
070 931 000 70x70x55x2,5	2,3,7,8	11,12,15,16,18,19	6,26	3,61
070 932 000 90x90x65x2,5	3,4,6,7,8,9,10,11	14,15,18,19,23,24	8,04	3,98
070 933 000 103x103x90x3,0	1,2,6,7,8,9,10,11,12,13	16,17,18,19,22,23,24,25,29,30	11,67	7,81

The table specifies the characteristic value of the load carrying capacity for a purlin connection with only one angle joint. In the case of load case F_4 , force facing towards to the angle.

Table 6: Basic Forces F_5 , 1 angle bracket / connection, Timber to timber

Bracket number	Nail number n_V	Nail number n_H	$F_{5,Rk}$ [kN]	
			Timber	Steel
070 931 000 70x70x55x2,5	2,3,7,8	11,12,15,16,18,19	1,57	1,41
070 932 000 90x90x65x2,5	3,4,6,7,8,9,10,11	14,15,18,19,23,24	2,13	1,82
070 933 000 103x103x90x3,0	1,2,6,7,8,9,10,11,12,13	16,17,18,19,22,23,24,25,29,30	3,16	3,66

The table **Table 6** specifies the characteristic value of the load carrying capacity for a purlin connection with only one angle joint. In the case of load case F_5 , force is averted from the angle.

Stainless steel brackets**Table 7:** Force F_1 Column, 2 angle brackets / connection, stainless steel, Timber to timber

Bracket number	Nail number n_V	Nail number n_H	$F_{1,Rk}$ [kN] (column)	
			Timber	Steel
070 924 000 70x70x55x2,0	1,2,3	11,12,15,16,18,19	2,20	1,20
070 924 000 70x70x55x2,5	1,2,3	11,12,15,16,18,19	2,20	1,88
070 925 000 90x90x65x2,5	1,2,6,7	15,16,17,20,21,25,26	3,59	1,33
070 925 000 90x90x65x2,0	1,2,6,7	15,16,17,20,21,25,26	3,59	2,08
070 926 000 103x103x90x2,5	1,2,4,5,6,7,8,9	20,21,22,23,26,27,28,29,31,32,33,34	5,02	3,09
070 926 000 103x103x90x3,0	1,2,4,5,6,7,8,9	20,21,22,23,26,27,28,29,31,32,33,34	5,02	4,45
070 929 000 90x90x40x2,0	1,2,4,5	11,12,14,15,16,17,19,20	2,39	0,80
070 929 000 90x90x40x2,5	1,2,4,5	11,12,14,15,16,17,19,20	2,39	1,25
070 931 000 70x70x55x2,0	1,2,3	11,12,15,16,18,19	2,64	2,47
070 931 000 70x70x55x2,5	1,2,3	11,12,15,16,18,19	3,18	3,33
070 932 000 90x90x65x2,0	1,2,6,7	14,15,18,19,23,24	3,62	3,28
070 932 000 90x90x65x2,5	1,2,6,7	14,15,18,19,23,24	4,05	4,35
070 933 000 103x103x90x2,5	1,2,6,7	16,17,18,19,22,23,24,25,29,30	5,71	13,40
070 933 000 103x103x90x3,0	1,2,6,7	16,17,18,19,22,23,24,25,29,30	5,72	15,90

The table contains the characteristic values of the load carrying capacity for a column connection. Values must be halved for one joint per connection.

Table 8: Force F_1 Purlin, 2 angle brackets / connection, stainless steel, Timber to timber

Bracket number	Nail number n_V	Nail number n_H	$F_{1,Rk}$ [kN] (purlin)	
			Timber	Steel
070 924 000 70x70x55x2,0	2,3,7,8	11,12,15,16,18,19	2,20	1,20
070 924 000 70x70x55x2,5	2,3,7,8	11,12,15,16,18,19	2,20	1,88
070 925 000 90x90x65x2,5	3,4,6,7,8,9,10,11	15,16,17,20,21,25,26	3,59	1,33

070 925 000 90x90x65x2,0	3,4,6,7,8,9,10,11	15,16,17,20,21,25,26	3,59	2,08
070 926 000 103x103x90x2,5	1,2,4,5,6,7,8,9, 10,11,12,13,14,15,16,17	20,21,22,23,26,27,28,29,31,32,33,34	5,02	3,09
070 926 000 103x103x90x3,0	1,2,4,5,6,7,8,9, 10,11,12,13,14,15,16,17	20,21,22,23,26,27,28,29,31,32,33,34	5,02	4,45
070 929 000 90x90x40x2,0	1,2,4,5,6,7	11,12,14,15,16,17,19,20	2,39	0,80
070 929 000 90x90x40x2,5	1,2,4,5,6,7	11,12,14,15,16,17,19,20	2,39	1,25
070 931 000 70x70x55x2,0	2,3,7,8	11,12,15,16,18,19	2,64	2,47
070 931 000 70x70x55x2,5	2,3,7,8	11,12,15,16,18,19	3,18	3,33
070 932 000 90x90x65x2,0	3,4,6,7,8,9,10,11	14,15,18,19,23,24	3,62	3,28
070 932 000 90x90x65x2,5	3,4,6,7,8,9,10,11	14,15,18,19,23,24	4,05	4,35
070 933 000 103x103x90x2,5	1,2,6,7,8,9,10,11,12,13	16,17,18,19,22,23,24,25,29,30	5,71	13,40
070 933 000 103x103x90x3,0	1,2,6,7,8,9,10,11,12,13	16,17,18,19,22,23,24,25,29,30	5,72	15,90

The table contains the characteristic values of the load carrying capacity for a purlin connection. Values must be halved for one joint per connection.

Table 9: Forces $F_{2,3}$, 2 angle brackets / connection, stainless steel, Timber to timber

Bracket number	Nail number n_V	Nail number n_H	$F_{2,3,Rk}$ [kN]
			Timber
070 924 000 70x70x55x2,0	2,3,7,8	11,12,15,16,18,19	5,93
070 924 000 70x70x55x2,5	2,3,7,8	11,12,15,16,18,19	5,89
070 925 000 90x90x65x2,5	3,4,6,7,8,9,10,11	15,16,17,20,21,25,26	8,74
070 925 000 90x90x65x2,0	3,4,6,7,8,9,10,11	15,16,17,20,21,25,26	8,68
070 926 000 103x103x90x2,5	1,2,4,5,6,7,8,9, 10,11,12,13,14,15,16,17	20,21,22,23,26,27,28,29,31,32,33,34	15,60
070 926 000 103x103x90x3,0	1,2,4,5,6,7,8,9, 10,11,12,13,14,15,16,17	20,21,22,23,26,27,28,29,31,32,33,34	15,50
070 929 000 90x90x40x2,0	1,2,4,5,6,7	11,12,14,15,16,17,19,20	5,44
070 929 000 90x90x40x2,5	1,2,4,5,6,7	11,12,14,15,16,17,19,20	5,41

070 931 000 70x70x55x2,0	2,3,7,8	11,12,15,16,18,19	5,93
070 931 000 70x70x55x2,5	2,3,7,8	11,12,15,16,18,19	5,89
070 932 000 90x90x65x2,0	3,4,6,7,8,9,10,11	14,15,18,19,23,24	7,78
070 932 000 90x90x65x2,5	3,4,6,7,8,9,10,11	14,15,18,19,23,24	7,72
070 933 000 103x103x90x2,5	1,2,6,7,8,9,10,11,12,13	16,17,18,19,22,23,24,25,29,30	11,60
070 933 000 103x103x90x3,0	1,2,6,7,8,9,10,11,12,13	16,17,18,19,22,23,24,25,29,30	11,50

The table contains the characteristic values of the load carrying capacity for a purlin connection. Values must be halved for one joint per connection.

Table 10: Basic Forces $F_{4,5}$, 2 angle brackets / connection, stainless steel, Timber to timber

Bracket number	Nail number n_V	Nail number n_H	$F_{4,5,Rk}$ [kN]	
			Timber	Steel
070 924 000 70x70x55x2,0	2,3,7,8	11,12,15,16,18,19	5,49	2,72
070 924 000 70x70x55x2,5	2,3,7,8	11,12,15,16,18,19	5,24	3,57
070 925 000 90x90x65x2,5	3,4,6,7,8,9,10,11	15,16,17,20,21,25,26	6,49	3,05
070 925 000 90x90x65x2,0	3,4,6,7,8,9,10,11	15,16,17,20,21,25,26	6,87	3,96
070 926 000 103x103x90x2,5	1,2,4,5,6,7,8,9, 10,11,12,13,14,15,16,17	20,21,22,23,26,27,28,29,31,32,33,34	10,10	5,71
070 926 000 103x103x90x3,0	1,2,4,5,6,7,8,9, 10,11,12,13,14,15,16,17	20,21,22,23,26,27,28,29,31,32,33,34	11,40	7,47
070 929 000 90x90x40x2,0	1,2,4,5,6,7	11,12,14,15,16,17,19,20	3,87	1,72
070 929 000 90x90x40x2,5	1,2,4,5,6,7	11,12,14,15,16,17,19,20	4,80	2,25
070 931 000 70x70x55x2,0	2,3,7,8	11,12,15,16,18,19	5,48	3,68
070 931 000 70x70x55x2,5	2,3,7,8	11,12,15,16,18,19	5,51	4,65
070 932 000 90x90x65x2,0	3,4,6,7,8,9,10,11	14,15,18,19,23,24	7,42	4,75
070 932 000 90x90x65x2,5	3,4,6,7,8,9,10,11	14,15,18,19,23,24	7,17	5,42
070 933 000 103x103x90x2,5	1,2,6,7,8,9,10,11,12,13	16,17,18,19,22,23,24,25,29,30	10,40	9,19

070 933 000 103x103x90x3,0	1,2,6,7,8,9,10,11,12,13	16,17,18,19,22,23,24,25,29,30	10,60	10,70
-------------------------------	-------------------------	-------------------------------	-------	-------

The table contains the characteristic values of the load carrying capacity for a purlin connection. Load case $F_{4/5}$ describes a connection with two angle joints per connection. The component 2 is allowed to be restrained against rotation by the angle brackets. In this case, an additional force ΔF_1 has to be considered.

Table 11: Basic Forces F_4 , 1 angle bracket / connection, stainless steel, Timber to timber

Bracket number	Nail number n_V	Nail number n_H	$F_{4,Rk}$ [kN]	
			Timber	Steel
070 931 000 70x70x55x2,0	2,3,7,8	11,12,15,16,18,19	6,07	2,67
070 931 000 70x70x55x2,5	2,3,7,8	11,12,15,16,18,19	6,26	3,47
070 932 000 90x90x65x2,0	3,4,6,7,8,9,10,11	14,15,18,19,23,24	7,44	3,46
070 932 000 90x90x65x2,5	3,4,6,7,8,9,10,11	14,15,18,19,23,24	8,04	3,82
070 933 000 103x103x90x2,5	1,2,6,7,8,9,10,11,12,13	16,17,18,19,22,23,24,25,29,30	11,42	6,50
070 933 000 103x103x90x3,0	1,2,6,7,8,9,10,11,12,13	16,17,18,19,22,23,24,25,29,30	11,67	7,50

The table specifies the characteristic value of the load carrying capacity for a purlin connection with only one angle joint. In the case of load case F_4 , force facing towards to the angle.

Table 12: Basic Forces F_5 , 1 angle bracket / connection, stainless steel, Timber to timber

Bracket number	Nail number n_V	Nail number n_H	$F_{5,Rk}$ [kN]	
			Timber	Steel
070 931 000 70x70x55x2,0	2,3,7,8	11,12,15,16,18,19	1,50	1,02
070 931 000 70x70x55x2,5	2,3,7,8	11,12,15,16,18,19	1,57	1,35
070 932 000 90x90x65x2,0	3,4,6,7,8,9,10,11	14,15,18,19,23,24	2,02	1,32
070 932 000 90x90x65x2,5	3,4,6,7,8,9,10,11	14,15,18,19,23,24	2,13	1,75
070 933 000 103x103x90x2,5	1,2,6,7,8,9,10,11,12,13	16,17,18,19,22,23,24,25,29,30	3,05	2,97
070 933 000 103x103x90x3,0	1,2,6,7,8,9,10,11,12,13	16,17,18,19,22,23,24,25,29,30	3,16	3,51

The table specifies the characteristic value of the load carrying capacity for a purlin connection with only one angle joint. In the case of load case F_5 , force is averted from the angle.

Definitions of forces, their directions and eccentricity

Forces - Beam to beam connection

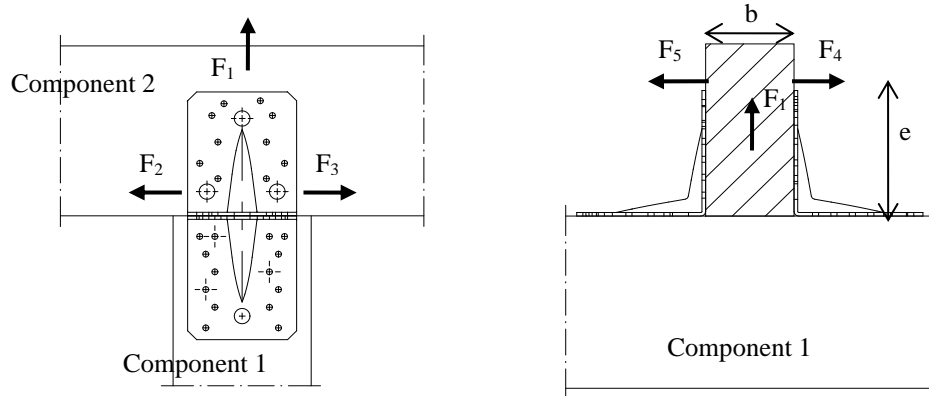

Fastener specification

Holes are marked with numbers referring to the nailing pattern in Annex A.

Double angle brackets per connection

The angle brackets must be placed at each side opposite to each other, symmetrically to the component axis.

Acting forces

- F_1 Lifting force acting along the central axis of the joint.
- F_2 and F_3 Lateral force acting in the joint between the component 2 and component 1 in the component 2 direction
- F_4 and F_5 Lateral force acting in the component 1 direction along the central axis of the joint. If the load is applied with an eccentricity e , a design for combined loading is required.

Single angle bracket per connection

Acting forces

- F_1 Lifting force acting in the central axis of the angle bracket. The component 2 shall be prevented from rotation. If the component 2 is prevented from rotation the load-carrying capacity will be half of a connection with double angle brackets.
- F_2 and F_3 Lateral force acting in the joint between the component 2 and the component 1 in the component 2 direction. The component 2 shall be prevented from rotation. If the component 2 is prevented from rotation the load-carrying capacity will be half of a connection with double angle brackets.
- F_4 and F_5 Lateral force acting in the component 1 direction in the height of the top edge of component 2. F_4 is the lateral force towards the angle bracket; F_5 is the lateral force away from the angle bracket. Only the characteristic load-carrying capacities for angle brackets with ribs are given.

Wane

Wane is not allowed, the timber has to be sharp-edged in the area of the angle brackets.

Timber splitting

For the lifting force F_1 it must be checked in accordance with Eurocode 5 or a similar national Timber Code that splitting will not occur.

Combined forces

If the forces F_1 and F_2/F_3 or F_4/F_5 act at the same time, the following inequality shall be fulfilled:

$$\left(\frac{F_{1,d}}{F_{Rd,1}}\right)^2 + \left(\frac{F_{2,d}}{F_{Rd,2}}\right)^2 + \left(\frac{F_{3,d}}{F_{Rd,3}}\right)^2 + \left(\frac{F_{4,d}}{F_{Rd,4}}\right)^2 + \left(\frac{F_{5,d}}{F_{Rd,5}}\right)^2 \leq 1$$

The forces F_2 and F_3 or F_4 and F_5 are forces with opposite direction. Therefore only one force F_2 or F_3 , and F_4 or F_5 , respectively, is able to act simultaneously with F_1 , while the other shall be set to zero.

If the load F_4/F_5 is applied with an eccentricity e , a design for combined loading **for connections with double angle brackets** is required. Here, an additional force ΔF_1 has to be added to the existing force F_1 .

$$\Delta F_{1,d} = F_{4,d} / F_{5,d} \cdot \frac{e}{B}$$

B is the width of component 2.